

# Z-M19/Z-W29 LED SIDE MARKER LAMP WITH REFLEX REFLECTOR

- ◆ M19 is generally used for the front, side and tail of special vehicles such as trailers, box trucks and mixers.
- ◆ Housing ABS (black), Lens PMMA (clear), With install brackets
- ◆ Optional: White, Red, and Amber;

**NEW**



## PRODUCT INFORMATION

Lamp function	Power Consumption	Current / Voltage	SMD	LED Q'TY	IP Grade	Compliance	LED color
Z-M19 Side marker lamp	0.5W	0.02A @ 24V	2835	6pcs	IP67	ECE R91 R10	● ● ○
Z-M19 Side marker + Direction Indicator	0.5W / 1W	0.02A/0.04A @ 24V	2835	12pcs	IP67	ECE R91 R6 R10	●
Z-W29 Side marker + Warning	0.5W / 10W	0.02A/0.42A @ 24V	2835	12pcs	IP67	ECE R91 XA1 R10	●

SIZE:  
[ mm ]

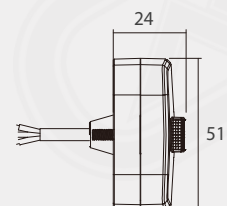
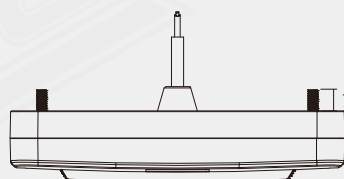
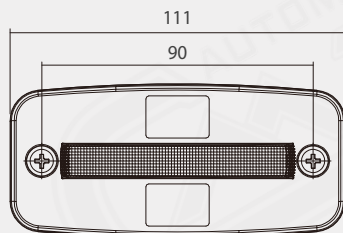

## LIGHTING



## APPLICATIONS



### Applications



## CONNECTION MODE

### Z-M19 Side marker lamp



### Z-M19 Side marker + Direction Indicator



### Z-W29 Side marker + Warning



## PRODUCT PACKAGING

### Z-M19/Z-W29

- White Box size: 125\*78\*70 mm
- Master Carton Size: 415\*270\*235 mm
- Quantity of Each Carton: 30 pcs
- Net Weight of Each Lamp: -- g
- Gross Weight per Carton: -- KG

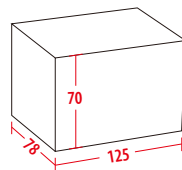

White box

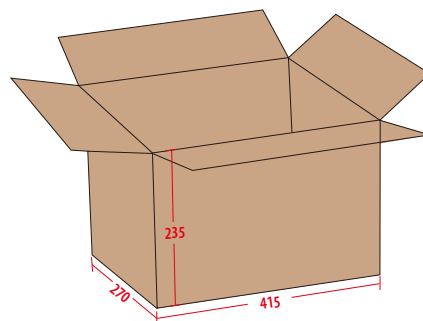

Outer box